

 TOPCON



**SIGNATURE SERIES**

*Model OC-2300*

# SIGNATURE SERIES

Model OC-2300

## Standard Chair Features

- Motorized recline
- Hydraulic low lift 9"(22.9cm) stroke with a maximum seat height of 29"(73.7cm) or hydraulic high lift 12.5"(31.8cm) stroke with a maximum seat height of 35"(88.9cm)
- User programmable memory two position control
- Illuminated membrane switch control on both chair sides
- Solid cast aluminum frame, armrest, footrest, and base
- One hand articulating headrest
- Securely locking hand brake with handle on both chair sides
- Ergonomically contoured cushions with anti-viral upholstery
- Self-lubricating hinges and bushings
- Foot pedal control
- Choice of upholstery colors

## Optional Features

- Surgical upholstery package
- Dual function foot pedal control

## Chair Dimensions and Specifications

### Movements

Elevation Stroke: 12.5"(31.8cm)/9"(22.9cm)

Rotation Angle: 355°

ETL Listed—Complies with UL and CSA Specifications

### Electrical

115 V, 60 Hz, 7 A

220 V, 50 Hz, 4 A

### Weight

Chair Capacity: 500 lbs.(226.8kg)

Shipping Wt: 286 lbs.(129.7kg)

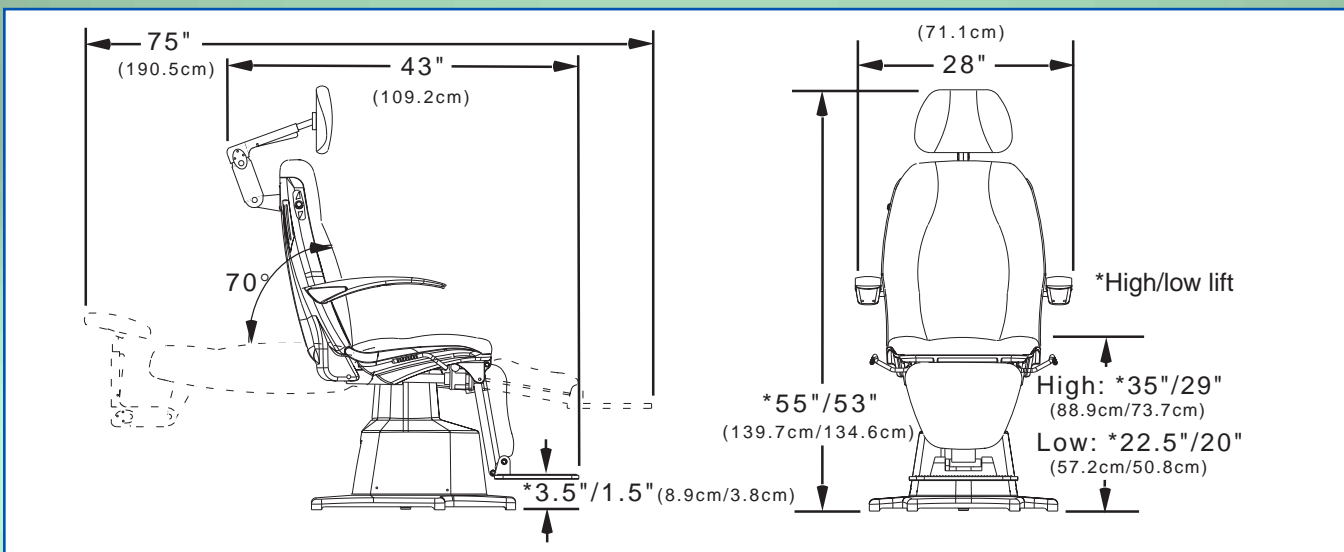

Dimensions and specifications are approximate and are subject to change without notice.